

Whirlwind is a heavy-duty double sided swing sign for displaying A1 size posters. The unit has a wheeled compact moulded base that can be filled with water or sand. The snap frame poster holders make changing your message extremely quick and simple.



### features & benefits

- Double sided
- Easy front loading aluminium snap frames
- Suitable for indoor or outdoor use
- Heavy-duty construction
- Wheeled compact moulded base that can be filled with water or sand
- Complete with protective graphics covers



Integral wheels make Whirlwind easy to move

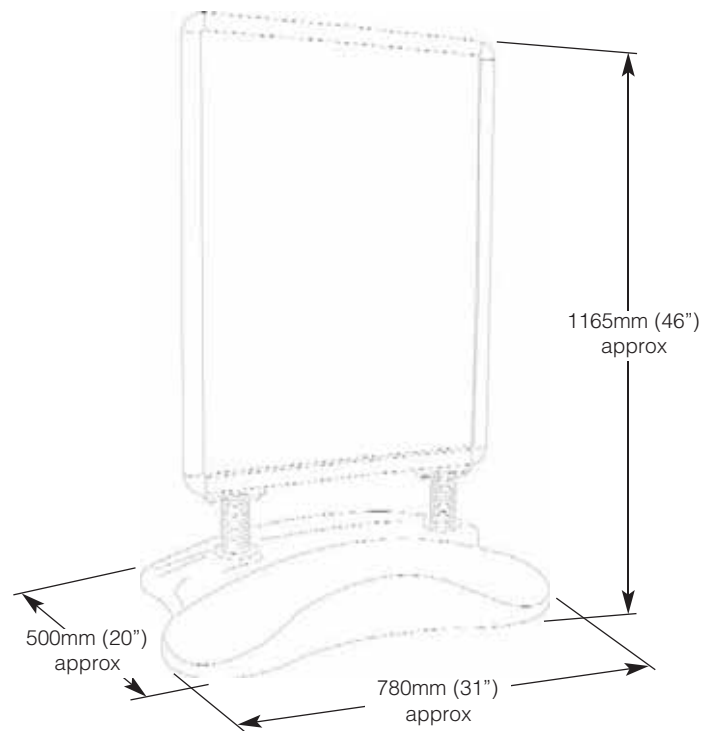

hardware specifications	graphic specifications	additional info
<p>Assembled dimensions: 1165mm (h) x 780mm (w) x 500mm (d) approx 46" (h) x 31" (w) x 20" (d) approx</p> <p>Weight: 11kg approx when empty &amp; 36kg approx when filled with water. (capacity 25 litres approx) 24.2lbs approx when empty &amp; 79.2 lbs approx when filled with water (capacity 6.60 US gallons approx)</p>	<p>Maximum Graphic Dimensions: 835mm (h) x 590mm (w) approx 33" (h) x 23" (w) approx</p> <p>Visible Graphic Dimensions: 820mm (h) x 575mm (w) approx 32.3" (h) x 22.6" (w) approx</p> <p>Substrate: 1mm (0.039") thick maximum For outdoor use encapsulate graphic or use suitable outdoor substrates</p>	<p>Availability: Aluminium frame with Anodised silver finish and grey moulded base.</p> <p>Note : When moving the unit do not drag the base. Tip unit onto it's wheels and pull or push to move.</p>